

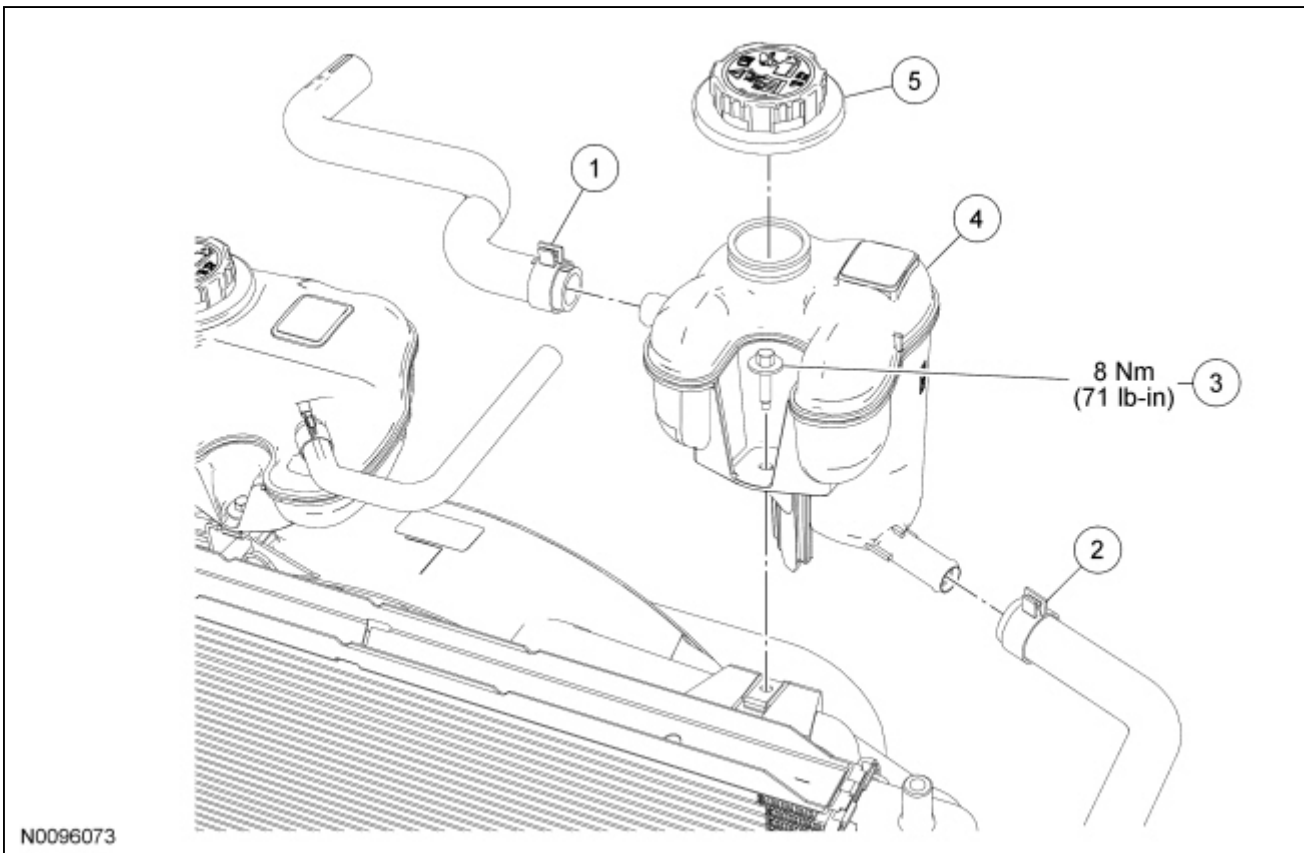

Degas Bottle



Item	Part Number	Description
1	8D031	Upper degas bottle hose
2	8D029	Lower degas bottle hose
3	W503924	Degas bottle bolt
4	8D028	Degas bottle
5	8100	Pressure relief cap

Removal and Installation

-  **WARNING:** Always allow the engine to cool before opening the cooling system. Do not unscrew the coolant pressure relief cap when the engine is operating or the cooling system is hot. The cooling system is under pressure; steam and hot liquid can come out forcefully when the cap is loosened slightly. Failure to follow these instructions may result in serious personal injury.

Release the pressure in the cooling system by slowly turning the pressure relief cap one half turn counterclockwise. When the pressure is released, remove the pressure relief cap.

- Using hose clamp pliers, clamp the lower degas bottle hose.
- Using a suction device, siphon the coolant from the degas bottle.
- Disconnect the upper degas bottle hose and position aside.
- Disconnect the lower degas bottle hose and position aside.

6. Remove the degas bottle bolt and remove the degas bottle.
 - To install, tighten to 8 Nm (71 lb-in).
 7. To install, reverse the removal procedure.
 8. Fill the degas bottle. For additional information, refer to [Supercharger Cooling System Draining, Filling and Bleeding](#) for the recommended coolant mixture and fill level.
-